

G1

SINGLE
GARAGE

1



25,7m²
Useable area

32,2m²
Build-up area

2%
Slop of the roff

3,2m
Building height

4,45mx7,25m
Min. dimentions
of the plot



ERH
ecoreadyhouse

VIZUALIZATION SHOWS EXAMPLE OF WINDOWS AND ELEVATIONS LAYOUT. ACTUAL FLOOR PLAN MAY BE DIFFERENT FROM VIZUALIZATION

G1

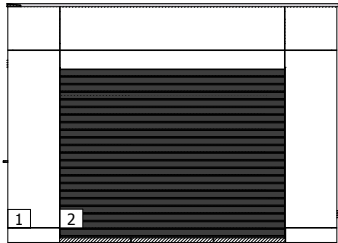

ELEVATION 1 SCALE 1:100

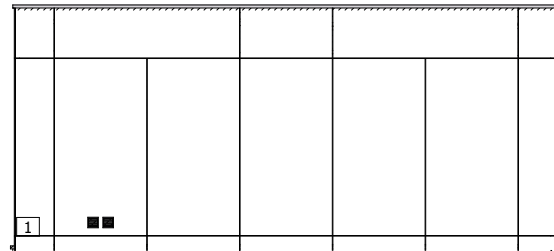

ELEVATION 2 SCALE 1:100

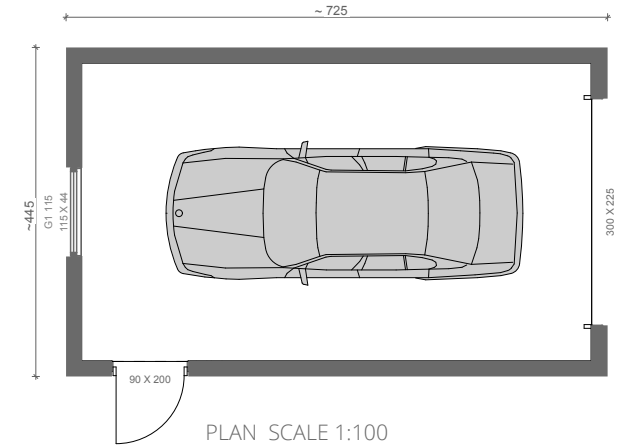

PLAN SCALE 1:100

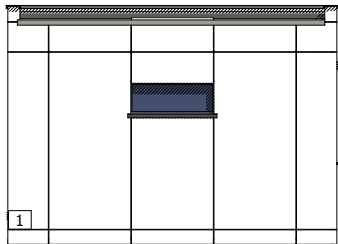

ELEVATION 3 SCALE 1:100

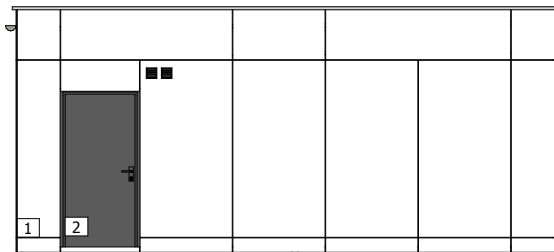

ELEVATION 4 SCALE 1:100

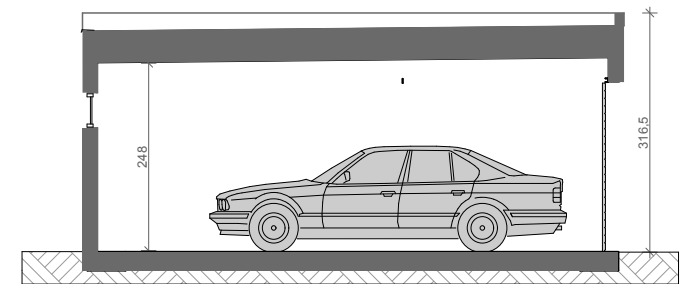

SECTION SCALE 1:100

- 1-EQUITONE TECTIVIA TE00
- 2-WINDOWS/ DOOR COLOUR CLOSE TO RAL 7016

* ALL ELEMENTS AND EQUIPMENT ARE NOT INCLUDED IN OFFER
SELECT THE PRINT OPTION 100% TO PRINT A SCALE OF 1:100

